

修改栏					
ECN	版次	修改内容	制定	审核	日期
	A	新出图	李自琳	黄兴军	9/5/2023

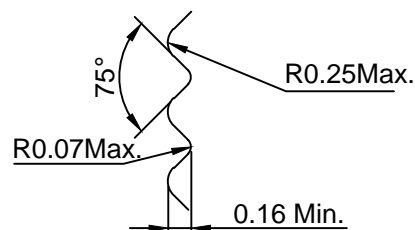

A 齿尖示意图

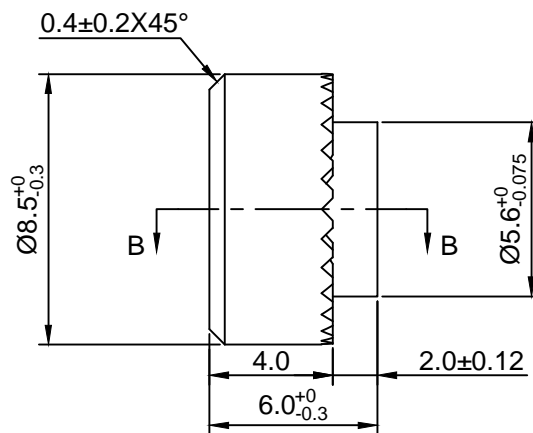
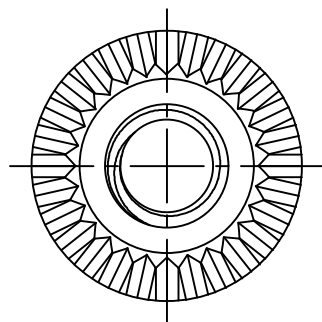
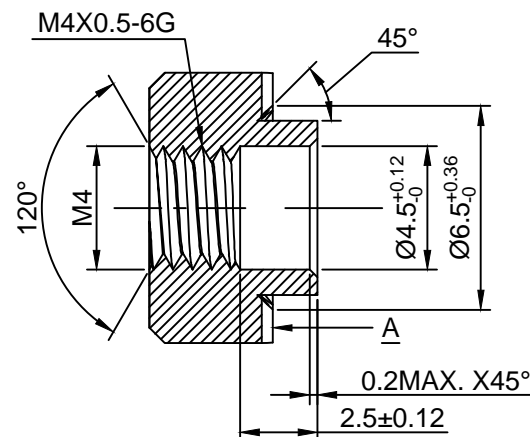

剖面:B-B

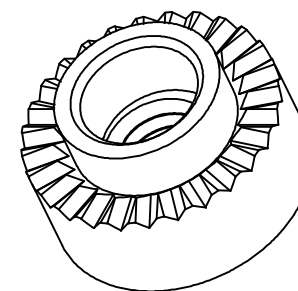

Notes:

- 1.材质: SUS304
- 2.表面处理:本色.
- 3.环保要求:

Pb<1000ppm Hg<1000ppm, Cd<100ppm, Cr6+<1000ppm.

TITLE:	M4花齿压铆不锈钢304螺母	CUSTOMER P/N:				
CUSTOMER TITLE:		MATERIAL:	SEE NOTES	DWG NO:		
CUSTOMER:		FINISH:	SEE NOTES	SCALE: 5:1	REV: A	
DRAWING BY:	李自琳 9/5/2023	TREATMENT	SEE NOTES	⊕	⊖	A4
CHECKED BY:	刘顺 9/5/2023	惠州市森浩科技有限公司 0752-3895008 0752-3895009				
APPROVED BY:	黄兴军 9/5/2023					