

外购图纸

REVISIONS					
ECN	REV	DESCRIPTION	CHK.	APP.	DATE
	A	NEW RELEASE	徐东辉	陈新华	12/10/2024

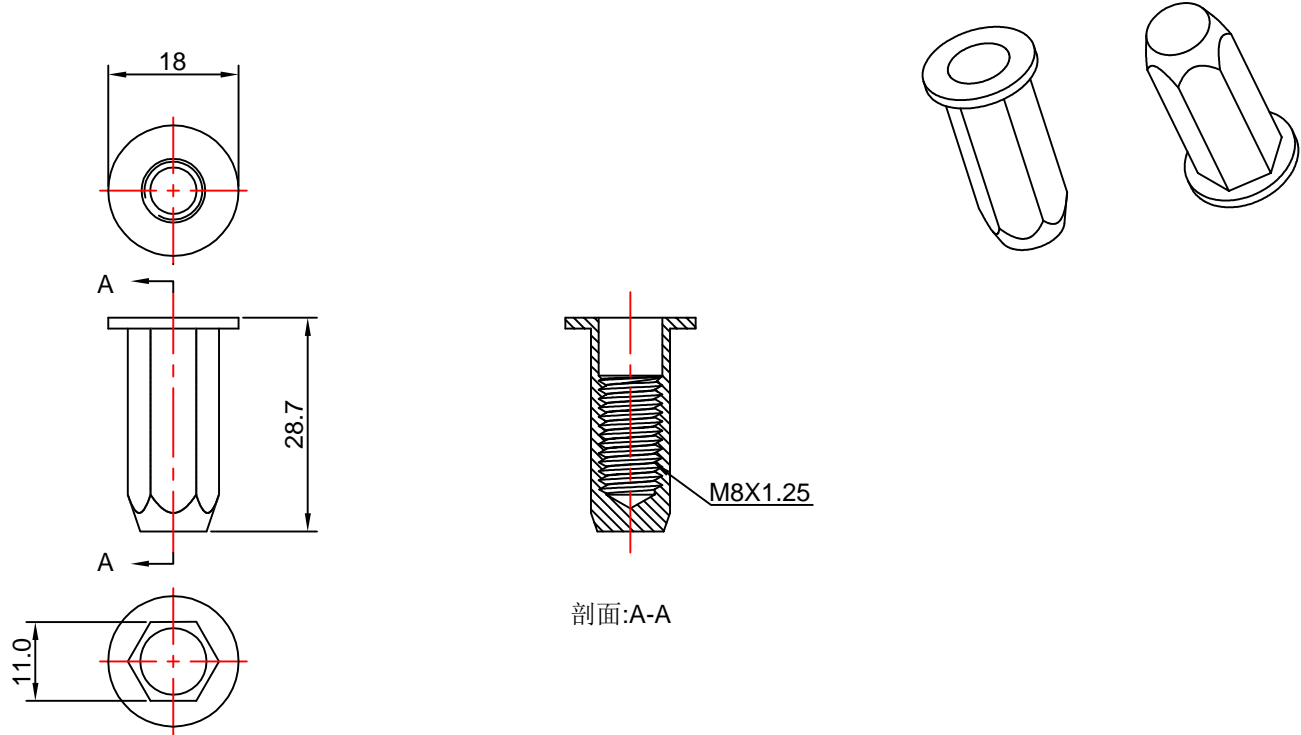

NOTES:

1. 材质: 不锈钢A2/等同于SUS304.
2. 表面处理: 钝化, 盐雾测试48小时
3. 环保要求:
Pb<1000PPM, Hg<1000ppm, Cd<100ppm, Cr6+=N.D.

TITLE:	M8X28.7不锈钢全六角拉铆螺母盲孔	CUSTOMER P/N:	14891		
CUSTOMER TITLE:		MATERIAL:	SEE NOTES	DWG NO.:	
CUSTOMER:	K06	FINISH:	SEE NOTES	SCALE: 1:1	REV: A
DRAWING BY:	徐东辉 12/10/2024	HEAT TREATMENT:	NONE	⊕ ⊖	A4
CHECKED BY:		 DongGuan Nisshi Industrial Co., Ltd TEL: 0769-85338896 FAX: 0769-85336186			
DATE:					
APPROVED BY:					
DATE:					